

## Kit Contents

- Remote receiver

## Important Safety Information

### DISCLAIMER: PLEASE NOTE INSTALLATION SHOULD BE CARRIED OUT BY A QUALIFIED ELECTRICIAN!

- Do wiring according to connection diagram correctly. Please power off and power on the device once a device mode is selected so that the selected mode can be activated.
- This Zigbee device is a wireless receiver that communicates with a variety of Zigbee compatible systems. This receiver receives and is controlled by wireless radio signals from the compatible Zigbee system.
- DO NOT install with power applied to device.
- DO NOT operate the dial switches for device mode selection with power applied to device.
- DO NOT expose the device to moisture.

## Function Introduction

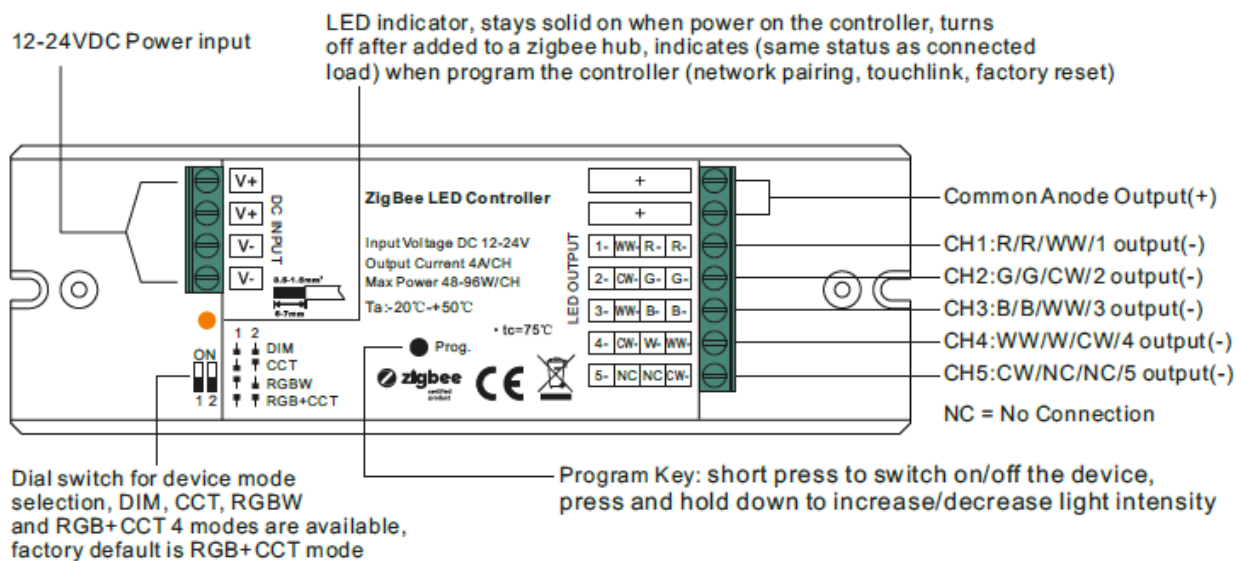

- 1) Under RGBW mode, W channel can be turned on through Gateway's colour temperature control interface which will mix RGB channels as 1 channel white and then make colour tuning with the 4th channel white. Once turned on, the brightness of white channel will be controlled together with RGB channels.
- 2) Under RGBW mode, W channel can be controlled separately from RGB channels through RGBW Zigbee remote or touch panel's W button. Please refer to their manuals.
- 3) Under RGB+CCT mode, RGB channels and tuneable white channels are controlled separately, they can not be turned on and controlled at the same time.

## Installation

### Zigbee Network Pairing through Coordinator or Hub (Added to a Zigbee Network)

- 1 Remove the device from previous Zigbee network if it has already been added to, otherwise pairing will fail. Please refer to the part "Factory Reset Manually".
- 2 From your Zigbee Controller or hub interface, choose to add lighting device and enter Pairing mode as instructed by the controller.
- 3 Reset power of the device to set it into network pairing mode (connected light flashes twice slowly), network pairing mode lasts 15S (enters into touchlink mode after 15S), once timeout, repeat this step.

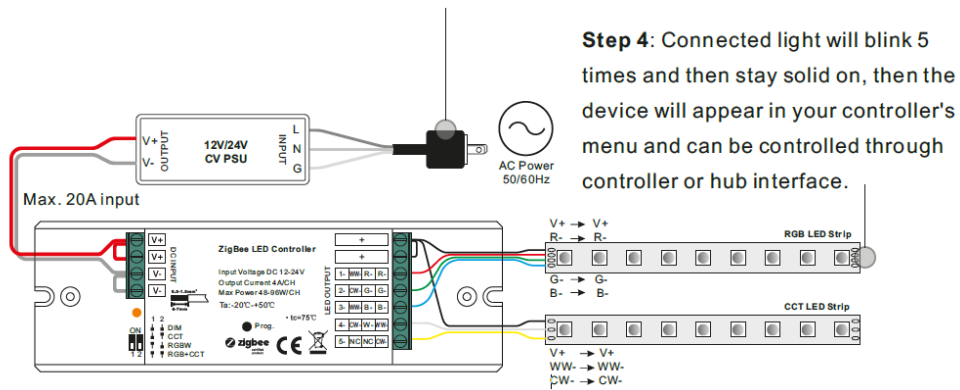

### TouchLink to a Zigbee Remote

- 1 **Method 1:** Short press "Prog" button 4 times (or re-power on the device 4 times) to start Touchlink commissioning (lasts for 180S) immediately under any circumstances, once time out, repeat this step. **Method 2:** Reset power of the device, Touchlink commissioning will start after 15S if it's not added to a Zigbee network, 165S timeout. Or start immediately if it's already added to a network, 180S timeout. Once timeout, repeat the step.

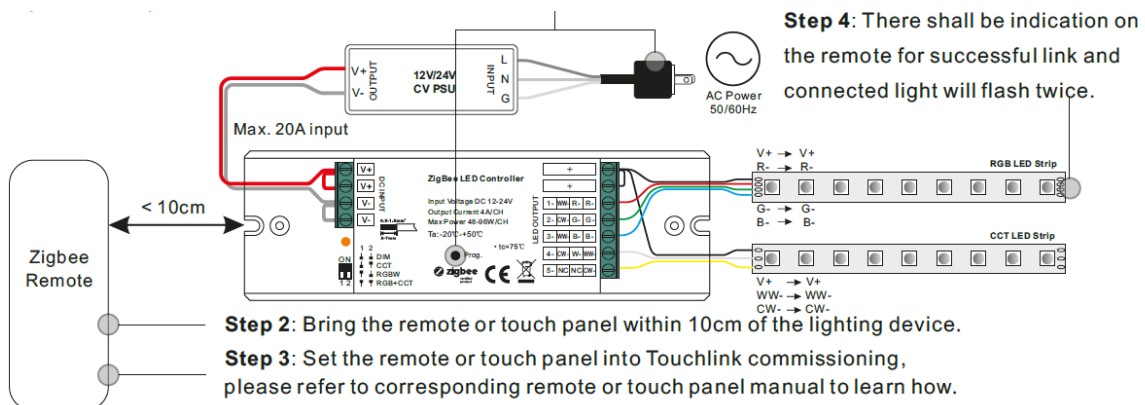



## Product Name: 5-In-1 Dimming Remote Receiver

- Note:** 1) Directly TouchLink (both not added to a Zigbee network), each device can link with 1 remote.  
 2) TouchLink after both added to a ZigBee network, each device can link with max. 30 remotes.  
 3) To control by both hub and remote, add remote and device to hub network first then TouchLink.  
 4) After TouchLink, the device can be controlled by the linked remotes.

### Removed from a Zigbee Network through Coordinator or Hub Interface

- From your Zigbee controller or hub interface, choose to delete or reset the lighting device as instructed. The connected light blinks 3 times to indicate successful reset.

### Factory Reset Manually

- Short press "Prog." key for 5 times continuously or reset power of the device for 5 times continuously if the "Prog." key is not accessible.

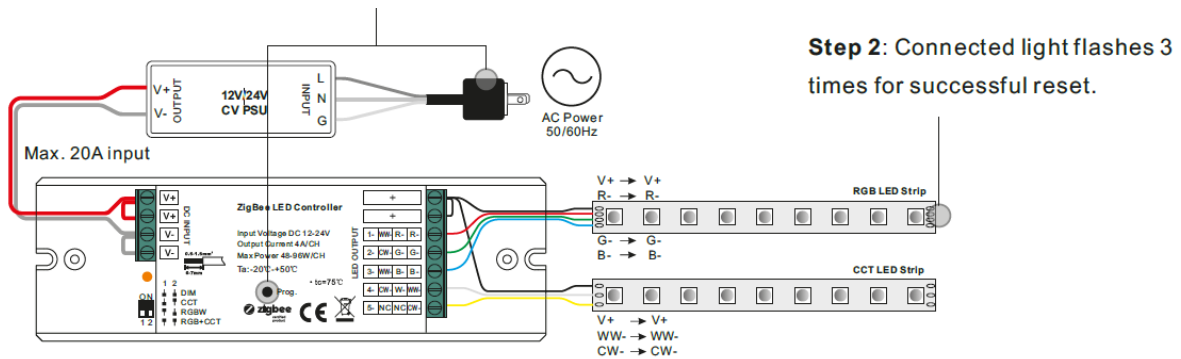

- Note:** 1) If the device is already at factory default setting, there is no indication when factory reset again.  
 2) All configuration parameters will be reset after the device is reset or removed from the network.

### Factory Reset through a Zigbee Remote (Touch Reset)

- Reset power of the device to start TouchLink Commissioning, 180 seconds timeout, repeat this step.

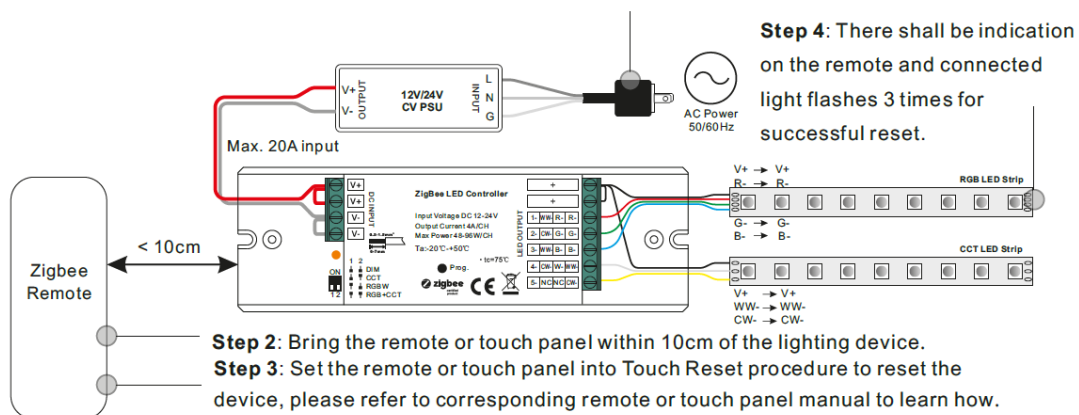

# Product Name: 5-In-1 Dimming Remote Receiver



## Installation Manual

**Note:** Make sure the device already added to a network, the remote added to the same one or not added to any network.

### Find and Bind Mode

- 1 Short press "Prog." button 3 times (Or reset power of the device (initiator node) 3 times) to start Find and Bind mode (connected light flashes slowly) to find and bind target node, 180 seconds timeout, repeat the step.

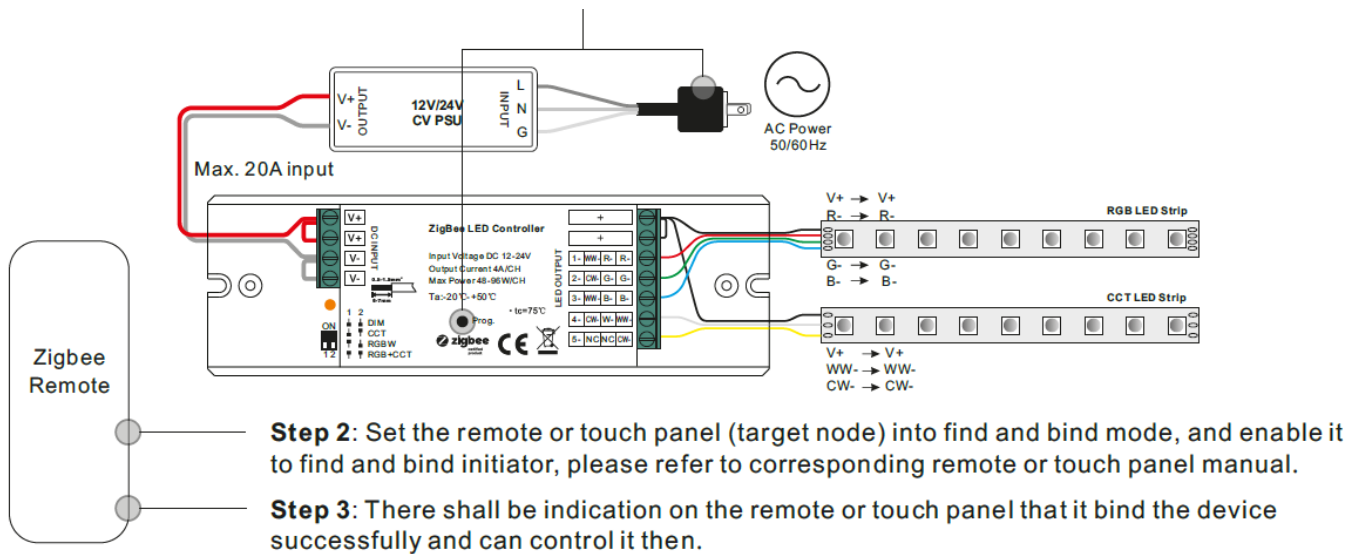

**Step 2:** Set the remote or touch panel (target node) into find and bind mode, and enable it to find and bind initiator, please refer to corresponding remote or touch panel manual.

**Step 3:** There shall be indication on the remote or touch panel that it bind the device successfully and can control it then.

**Note:** Make sure the device and the remote or touch panel already added to the same Zigbee hub.

### Learning to a Zigbee Green Power Remote

- 1 Short press "Prog." button 4 times (Or reset power of the device 4 times) to start Learning to GP switch mode (connected light flashes twice), 180 seconds timeout, repeat the step.

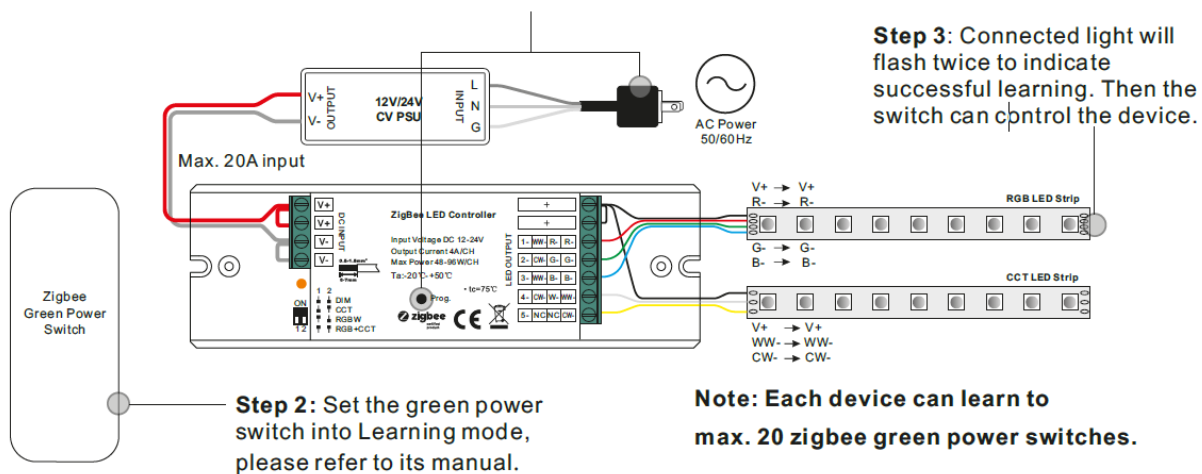

**Step 3:** Connected light will flash twice to indicate successful learning. Then the switch can control the device.

**Step 2:** Set the green power switch into Learning mode, please refer to its manual.

**Note:** Each device can learn to max. 20 zigbee green power switches.

## Delete Learning to a Zigbee Green Power Switch

- Short press "Prog." button 3 times (Or reset power of the device 3 times) to start delete Learning to GP switch mode (connected light flashes slowly), 180 seconds timeout, repeat the step.

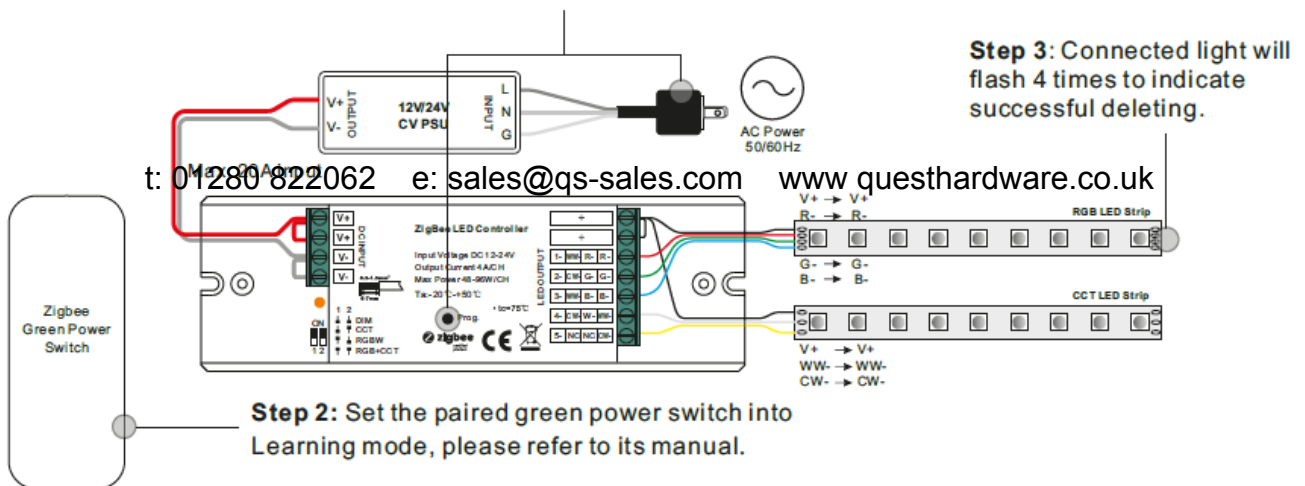

## Setup a Zigbee Network & Add Other Devices to the Network (No Coordinator Required)

- Short press "Prog." button 4 times (Or reset LED power of the device 4 times) to enable the device to setup a Zigbee network (connected light flashes twice) to discover and add other devices, 180 seconds timeout, repeat the step.

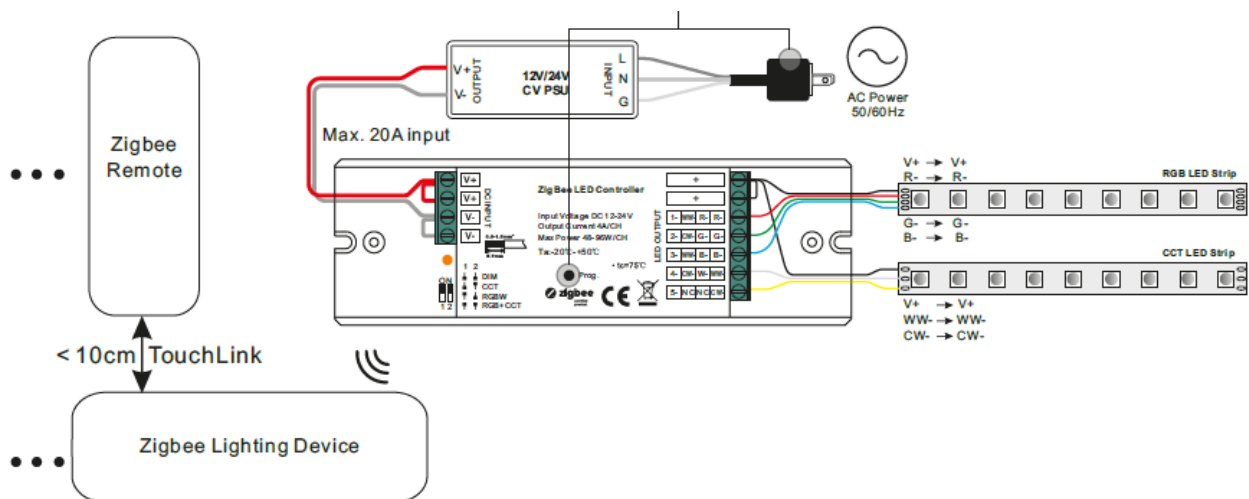

- Set another device or remote or touch panel into network pairing mode and pair to the network. Refer to their manuals.

**3** Pair more devices and remotes to the network as you would like. Refer to their manuals.

**4** Bind the added devices and remotes through Touchlink so that the devices can be controlled by the remotes. Refer to their manuals.

**Note:** 1) Each added device can link and be controlled by max. 30 added remotes.  
2) Each added remote can link and control max. 30 added devices.

### Wiring Diagram

#### 1) RGB+CCT Mode

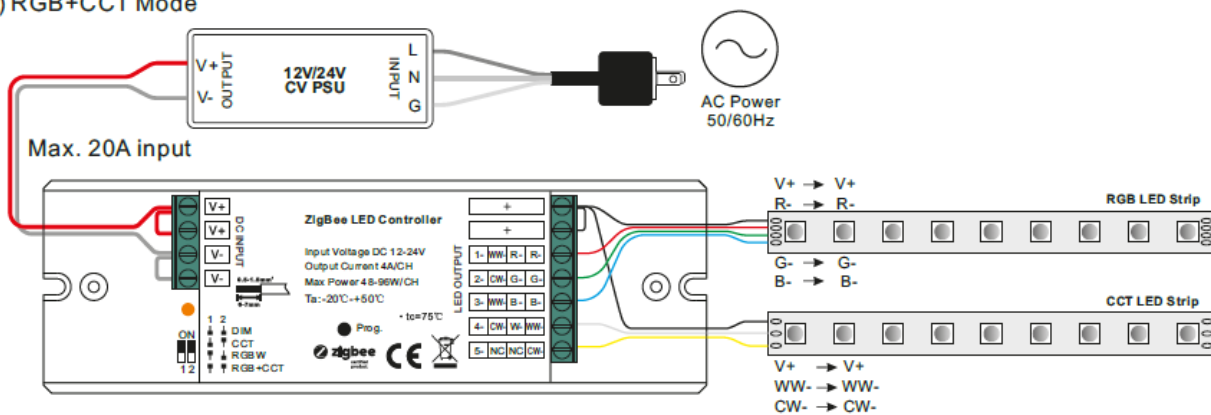

**Note:** please make sure the dial switches are at position for RGB+CCT mode as shown in above diagram.

#### 2) RGBW Mode

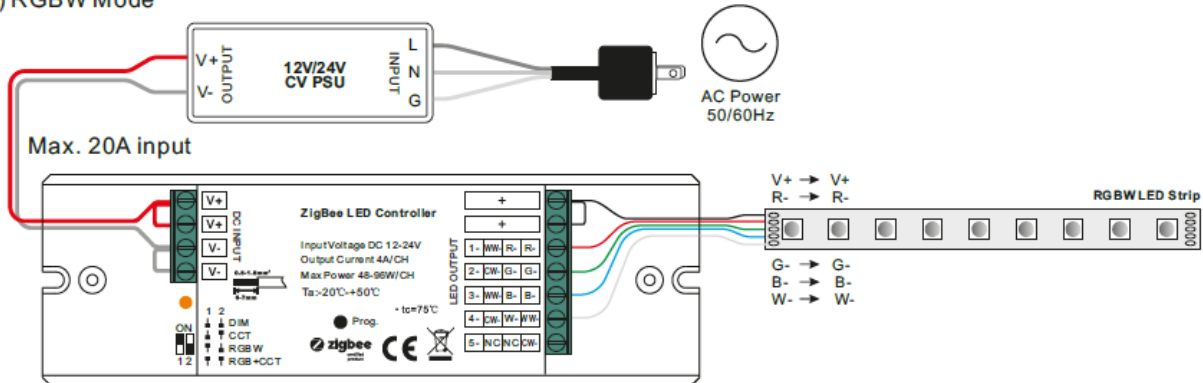

**Note:** please make sure the dial switches are at position for RGBW mode as shown in above diagram.

3) CCT Mode

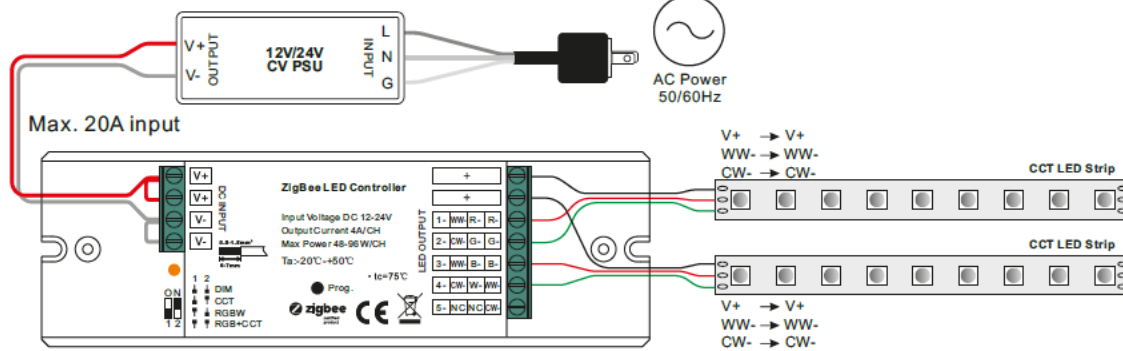

**Note:** please make sure the dial switches are at position for CCT mode as shown in above diagram.

4) DIM Mode

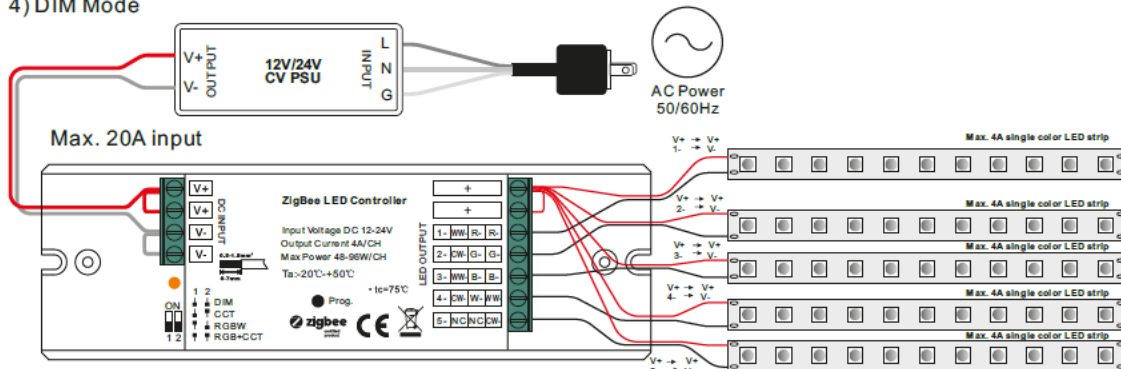

**Note:** please make sure the dial switches are at position for DIM mode as shown in above diagram.

Other Information

Specifications:

- 4 in 1 universal Zigbee LED controller based on latest Zigbee 3.0 protocol
- 4 different device modes DIM, CCT, RGBW and RGB+CCT in 1 controller, and selectable by dial switch
- Enables to control ON/OFF, light intensity, colour temperature, RGB colour of connected LED lights
- Can directly pair to a compatible Zigbee remote via Touchlink
- Supports self-forming Zigbee network without coordinator
- Supports find and bind mode to bind a Zigbee remote
- Supports Zigbee green power and can bind max. 20 Zigbee green power remotes
- Compatible with universal Zigbee gateway or hub products
- Compatible with universal Zigbee remotes
- Waterproof grade: IP20

Product Name: 5-In-1 Dimming Remote Receiver



Installation Manual

ZigBee Clusters the device supports are as follows:

**Input Clusters**

- 0x0000: Basic
- 0x0003: Identify
- 0x0004: Groups
- 0x0005: Scenes
- 0x0006: On/off
- 0x0008: Level Control
- 0x0300: Color Control
- 0x0b05: Diagnostics

**Output Clusters**

- 0x0019: OTA

**OTA**

The device supports firmware updating through OTA, and will acquire new firmware from Zigbee controller or hub every 10 minutes automatically.

**Product Dimensions:**

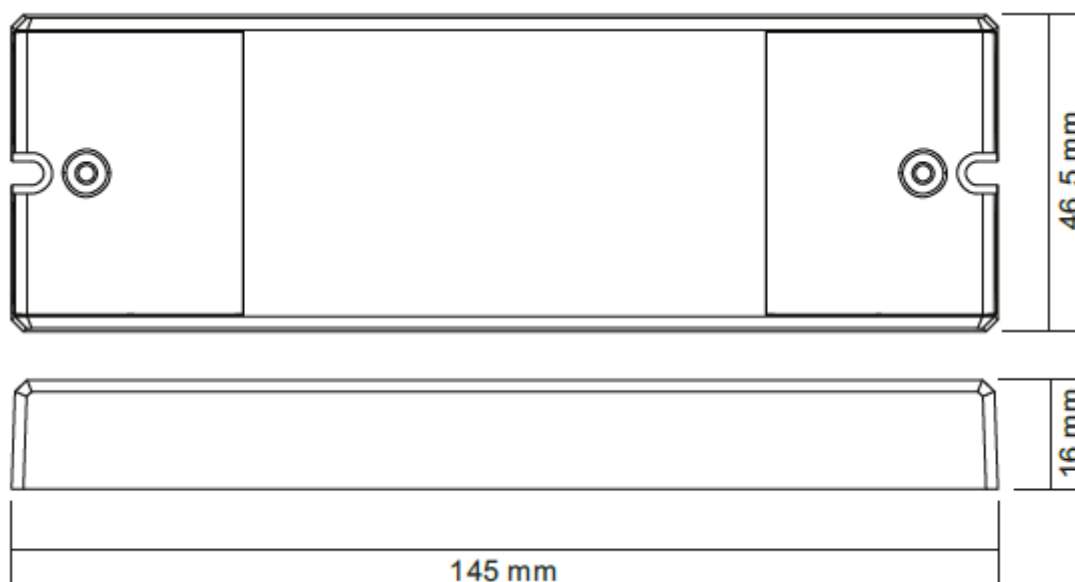

**Product Data**

Input Voltage	Output Current	Output Power	Remarks	Size(LxWxH)	Ambient Temperature	Max. Casing Temperature
12-24VDC	4A/CH	48-96W/CH	Constant voltage	145x46.5x16mm	-20°C ~ +50°C	75°C