

Kit Contents

- Remote receiver

Important Safety Information

DISCLAIMER: PLEASE NOTE INSTALLATION SHOULD BE CARRIED OUT BY A QUALIFIED ELECTRICIAN!

- This Zigbee RGB+CCT remote is a wireless transmitter that communicates with a variety of ZigBee compatible systems. This transmitter sends wireless radio signals that are used to remotely control a compatible system.
- This Zigbee remote supports 1 group for binding max. 30 lighting devices and enables to control both RGB and CCT ZigBee lighting devices.
- This device contains a button lithium battery that shall be stored and disposed properly.
- DO NOT expose the device to moisture.

Function Introduction

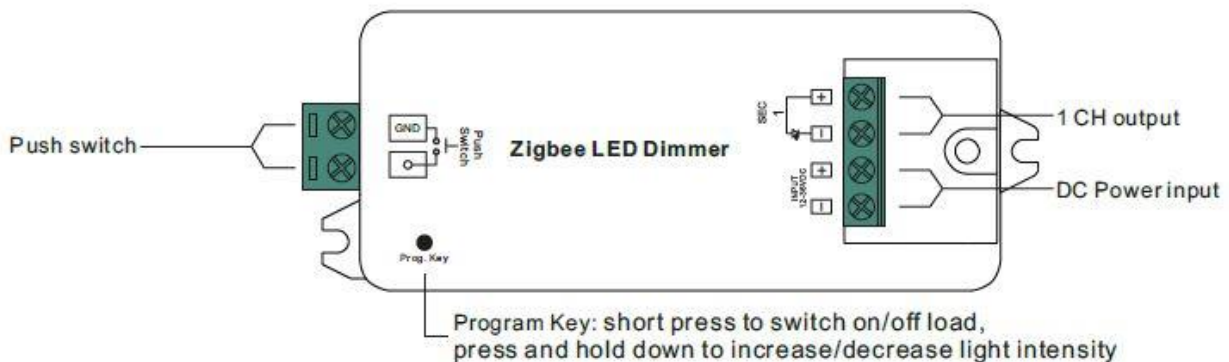

Installation

Zigbee Network Pairing through Coordinator or Hub (Added to a Zigbee Network)

1 Remove the device from any previous Zigbee network if it has already been added, otherwise the pairing will fail. Please refer to the part "Factory Reset Manually".

2 From your Zigbee Controller or hub interface, choose to add lighting device and enter Pairing mode as instructed by the controller.

- 3 Re-power on the device to set it into network pairing mode (connected light flashes twice slowly), 15 seconds timeout, repeat the operation.

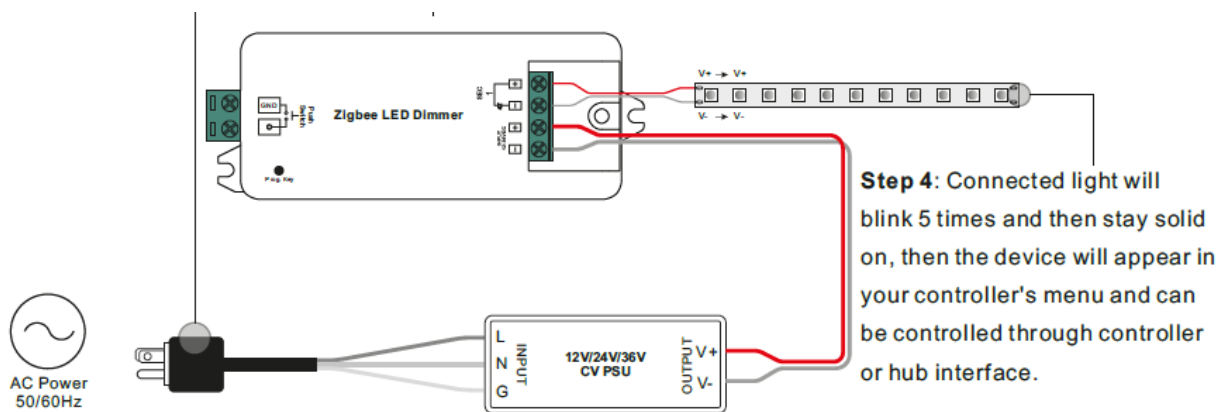

TouchLink to a Zigbee Remote

- 1 **Method 1:** Short press "Prog" button (or re-power on the device) 4 times to start Touchlink commissioning immediately, 180S timeout, repeat the operation.
Method 2: Re-power on the device, Touchlink commissioning will start after 15S if it's not added to a Zigbee network, 165S timeout. Or start immediately if it's already added to a network, 180S timeout. Once timeout, repeat the operation.

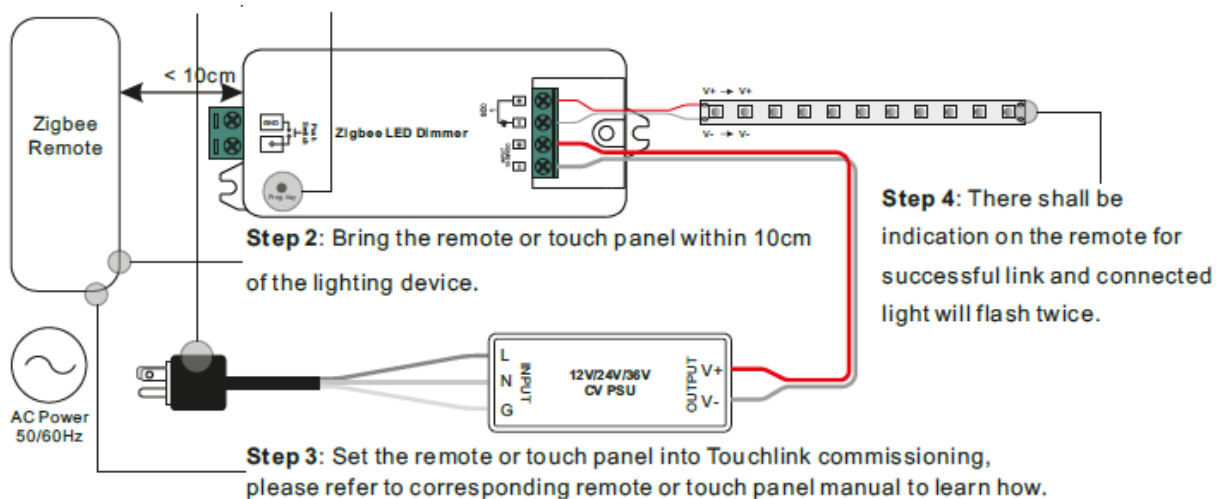

Product Name: Single Colour Dimming Remote Receiver



Installation Manual

- Note:** 1) Directly TouchLink (both not added to a Zigbee network), each device can link with 1 remote.
2) TouchLink after both added to a Zigbee network, each device can link with max. 30 remotes.
3) For Hue Bridge & Amazon Echo Plus, add remote and device to network first then TouchLink.
4) After TouchLink, the device can be controlled by the linked remotes.

Removed from a Zigbee Network through Coordinator or Hub Interface

- 1 Remove from a Zigbee Network through Coordinator or Hub Interface - From your Zigbee controller or hub interface, choose to delete or reset the lighting device as instructed. The connected light blinks 3 times to indicate successful reset.

Factory Reset Manually

- 1 Short press "Prog." key for 5 times continuously or re-power on the device for 5 times continuously if the "Prog." key is not accessible.

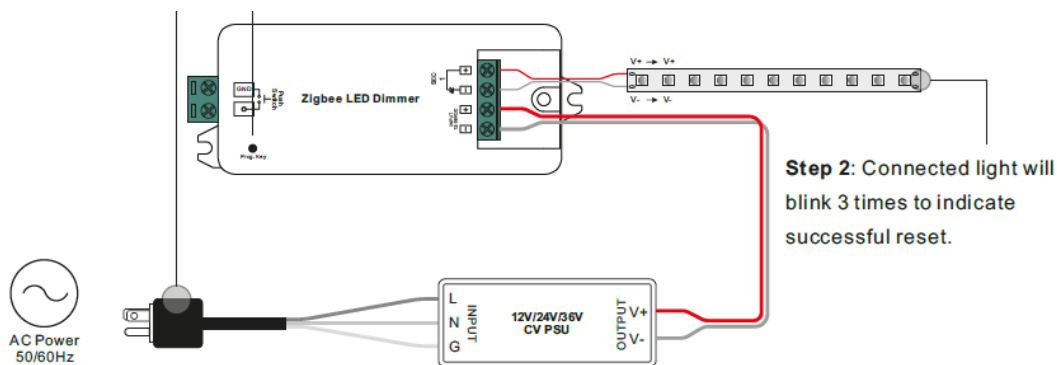

- Note:** 1) If the device is already at factory default setting, there is no indication when factory reset again.
2) All configuration parameters will be reset after the device is reset or removed from the network.

Factory Reset through a Zigbee Remote (Touch Reset)

- 1 Re-power on the device to start TouchLink Commissioning, 180 seconds timeout, repeat the operation.

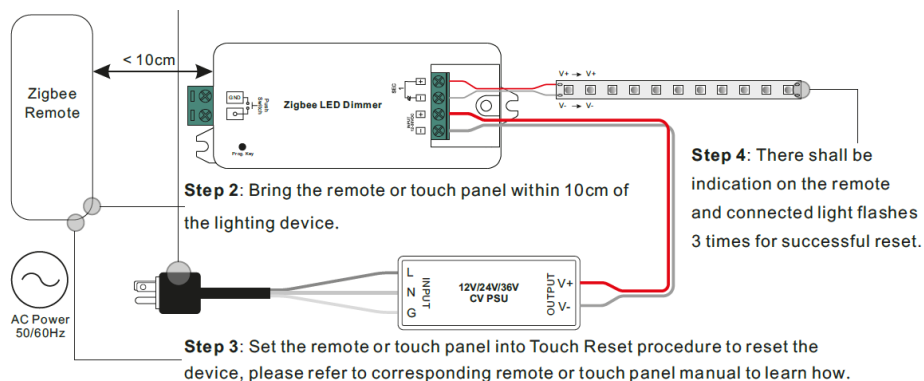

Product Name: Single Colour Dimming Remote Receiver



Installation Manual

Note: Make sure the device already added to a network, the remote added to the same one or not added to any network

Find and Bind Mode

- 1 Short press "Prog." button 3 times (Or re-power on the device (initiator node) 3 times) to start Find and Bind

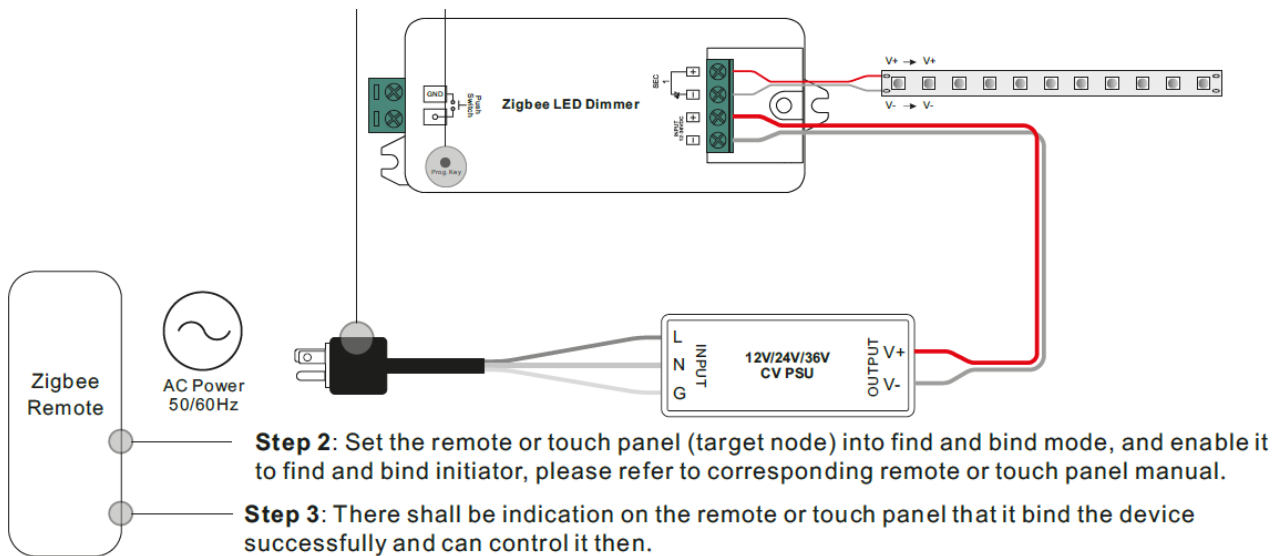

Learning to a Zigbee Green Power Remote

- 1 Short press "Prog." button 4 times (Or re-power on the device 4 times) to start Learning mode (connected light flashes twice), 180 seconds timeout, repeat the operation.

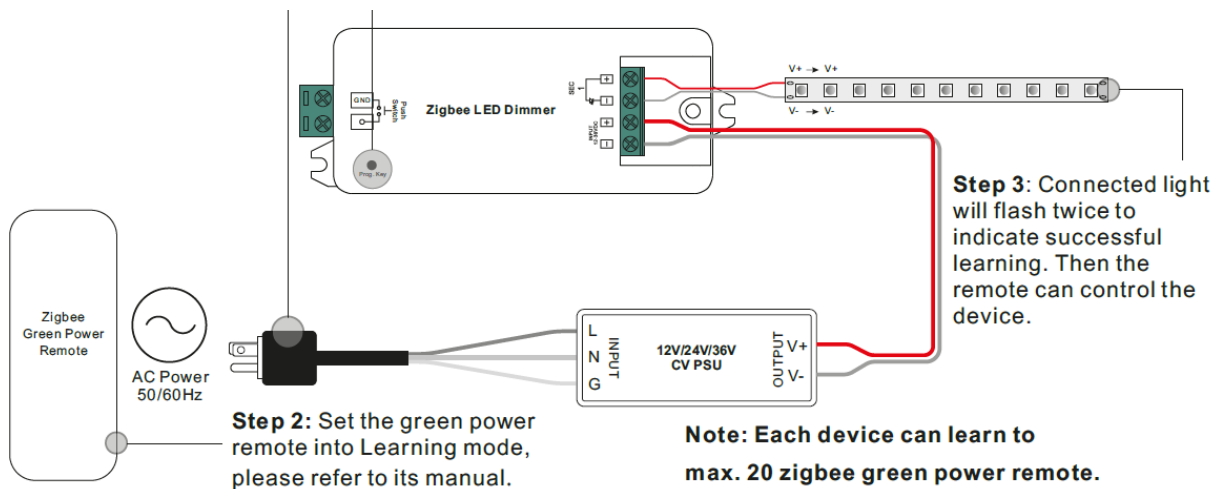

Delete Learning to a Zigbee Green Power Remote

- 1 Short press "Prog." button 3 times (Or re-power on the device 3 times) to start delete Learning mode (connected light flashes slowly), 180 seconds timeout, repeat the operation.

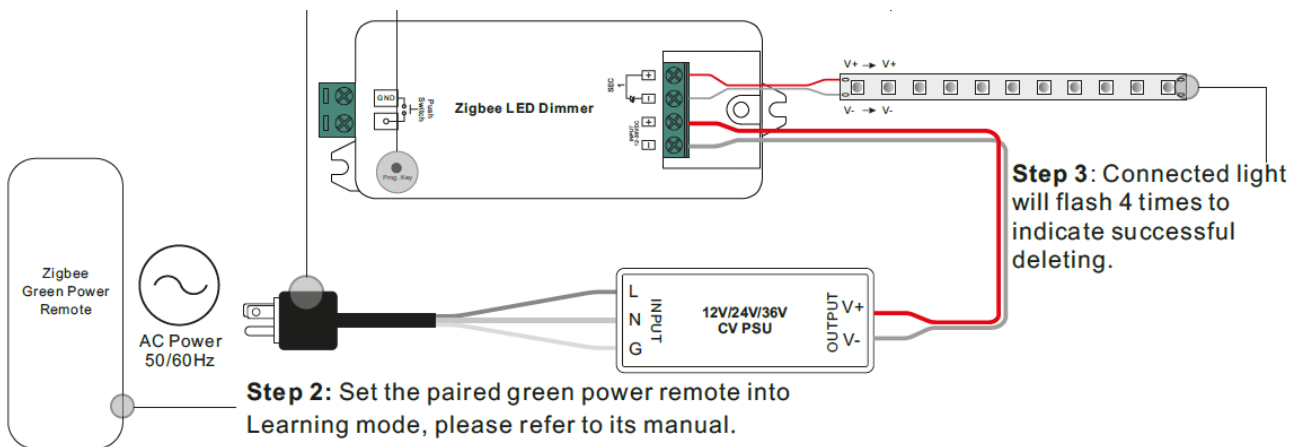

Setup a Zigbee Network & Add Other Devices to the Network (No Coordinator Required)

- 1 Short press "Prog." button 4 times (Or re-power on the device 4 times) to enable the device to setup a Zigbee network (connected light flashes twice) to discover and add other devices, 180 seconds timeout, repeat the operation.

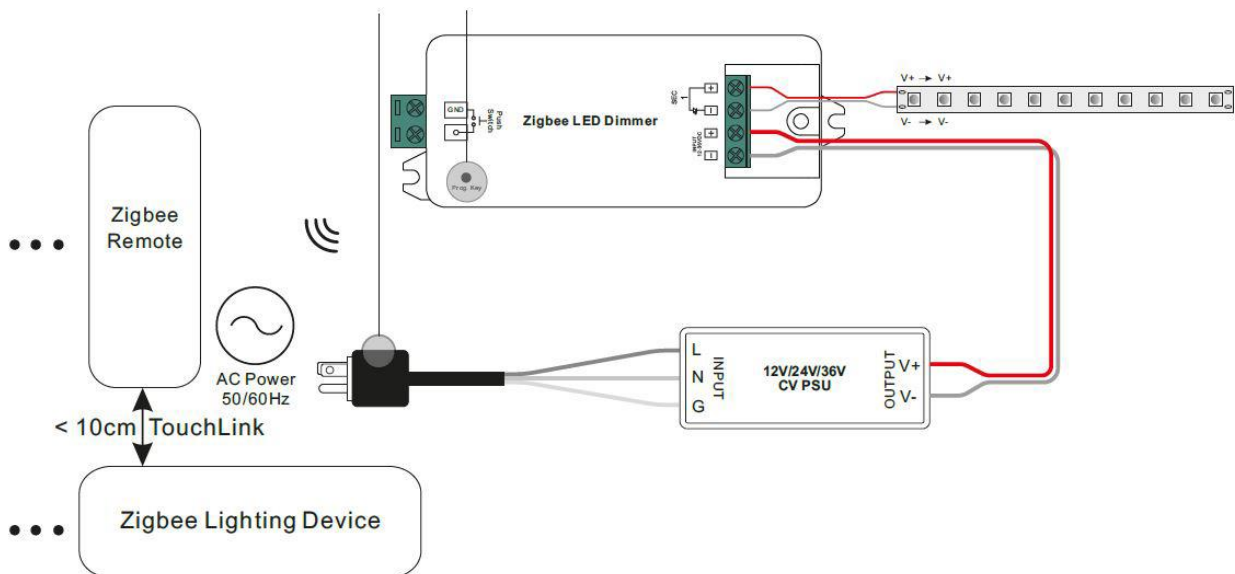

3 Pair more devices and remotes to the network as you would like. Refer to their manuals.

4 Bind the added devices and remotes through Touchlink so that the devices can be controlled by the remotes. Refer to their manuals.

Note: 1) Each added device can link and be controlled by max. 30 added remotes.
2) Each added remote can link and control max. 30 added devices.

Wiring Diagram

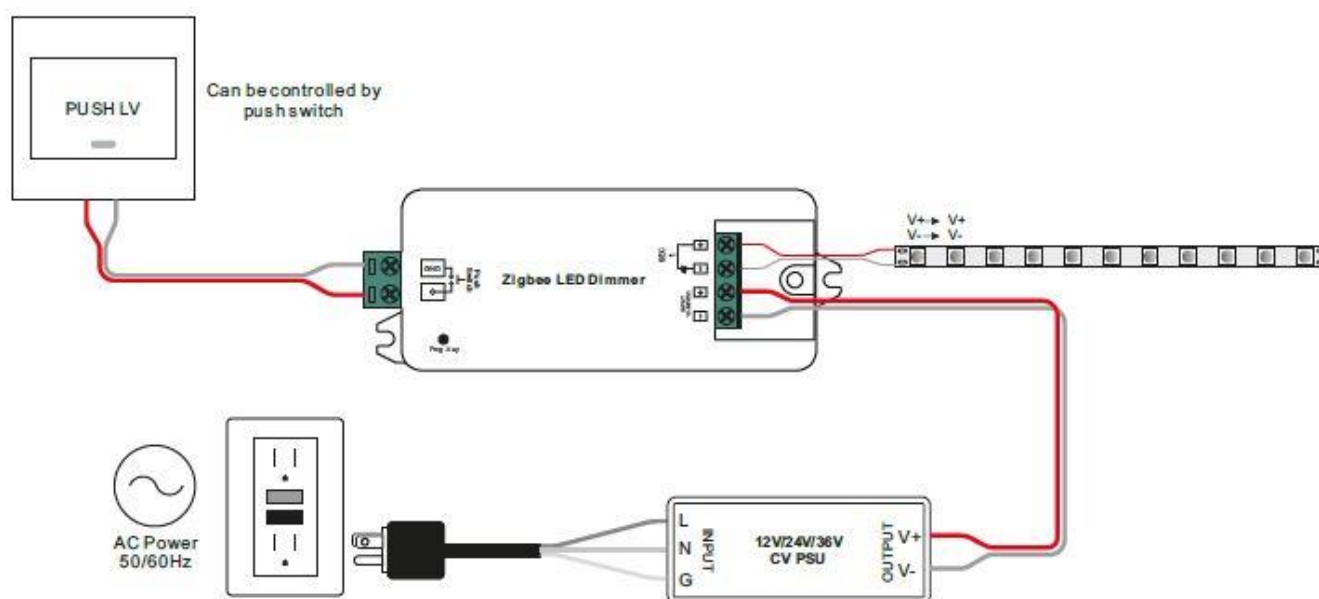

Other Information

Specifications:

- Zigbee LED dimming light device based on latest Zigbee 3.0 protocol
- Enables to control ON/OFF and light intensity of connected LED lights
- Zigbee end device that supports Touchlink commissioning
- Can directly pair to a compatible Zigbee remote via Touchlink without coordinator
- Supports self-forming Zigbee network without coordinator
- Enables to add devices to the self-formed Zigbee network
- Supports self-forming Zigbee network without coordinator and add other devices to the network
- Supports find and bind mode to bind a Zigbee remote
- Supports Zigbee green power and can bind max. 20 Zigbee green power remotes
- Compatible with universal Zigbee gateway products
- Waterproof grade: IP20



Product Name: Single Colour Dimming Remote Receiver

Zigbee Clusters the device supports are as follows:

Input Clusters

- 0x0000: Basic
- 0x0003: Identify
- 0x0004: Groups
- 0x0005: Scenes
- 0x0006: On/off
- 0x0008: Level Control
- 0x0b05: Diagnostics

Output Clusters

- 0x0019: OTA

OTA

The device supports firmware updating through OTA, and will acquire new firmware from Zigbee controller or hub every 10 minutes automatically.

Controlled by a push switch:

Once connected with a push switch, click the push switch to switch ON/OFF, press and hold down it to increase/decrease light intensity.

Product Dimensions:

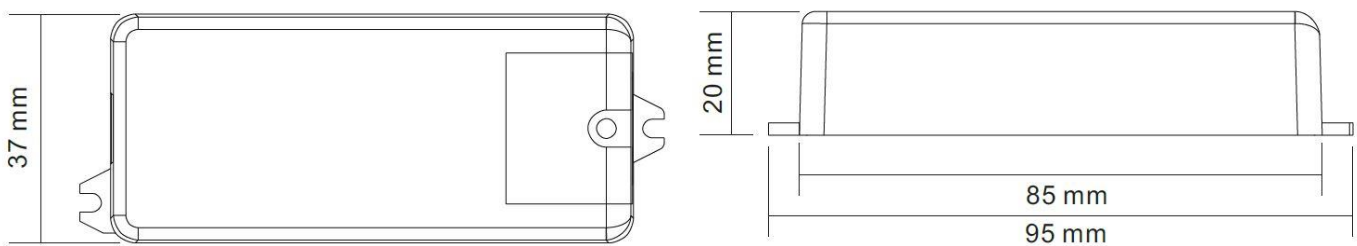

Product Data

No.	Input Voltage	Output Current	Output Power	Remarks	Size(LxWxH)
1	12-36VDC	1x8A	1x(96-288)W	Constant voltage	95x37x20mm
2	12-36VDC	1x350mA	1x(4.2-12.6)W	Constant current	95x37x20mm
3	12-36VDC	1x700mA	1x(8.4-25.2)W	Constant current	95x37x20mm